



NSK LINEAR GUIDES Miniature PU Series/PE Series

NSK Miniature Linear Guides, ideal for semiconductor manufacturing and medical equipment.



SUBSCRIBE TO NSK NEWSLETTER 

Smooth motion and unprecedented lightness

The advanced NSK Miniature Linear Guides

The new generation PU series/PE series inherit the outstanding lineage of the NSK miniature linear guides LU series/LE series. Improves dynamic friction characteristics and creates smoother motion with reduced noise intensity. The new design supports a wide variety of applications.

Features

1. Motion performance

Highly smooth operation is achieved by smooth ball recirculation.

2. Lightweight

The ball slide is designed to be approximately 20% lighter than conventional models* by using resin.

*Miniature LU series/LE series

3. Reduced noise intensity

Resin components applied in the ball circulating system reduce collision noise between steel balls and the inner wall of circulating circuits.

4. Low particle generation

The new design generates less particles compared to conventional models.

5. Excellent particle resistance

Compact space between the side of the rails and the inner walls of the ball slide prevents the entrance of foreign matter.

6. High corrosion resistance

Stainless steel is a standard feature that provides excellent corrosion resistance.

7. Easy handling

Design prevents steel balls from dropping out of the ball slide even when the slide is removed from the rail.

8. Long-term maintenance-free

Equipped with NSK K1™ Lubrication unit to extend product life.

9. Fast delivery

Wide selection of interchangeable rails and ball slides for PU/PE Series.

Miniature PU (Interchangeable with LU Series)



Wide Miniature PE (Interchangeable with LE Series)





PU09TR



PE09TR

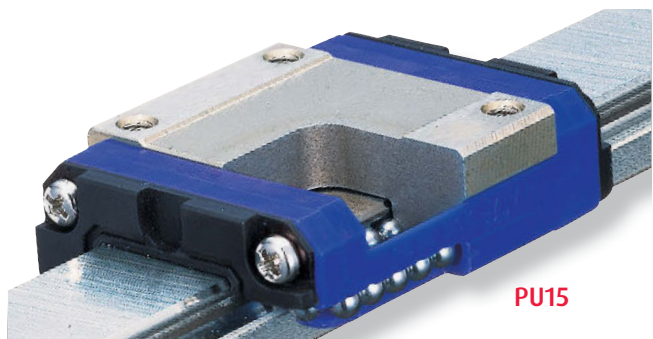

PU15

Cutaway View

Smoother motion

The resin ball recirculation component creates an optimal configuration, resulting in smoother motion.

Test conditions: Oil lubrication (VG68)
 Operating speed: 1 000 mm/min
 Load cell rated capacity: 5N

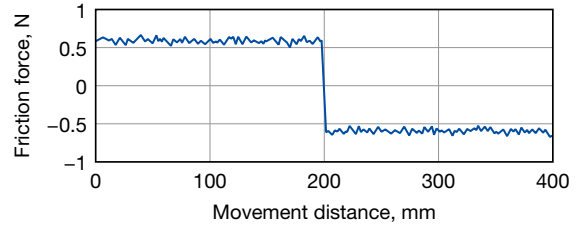

Fig. 1-1 Fluctuations in Dynamic Friction

Low particle generation

The PU series/PE series, with resin ball recirculation components, generates less particles than a conventional ball recirculation system.

Test conditions: Grease lubrication (LG2)
 Operating speed: 600 mm/min
 Stroke: 200 mm

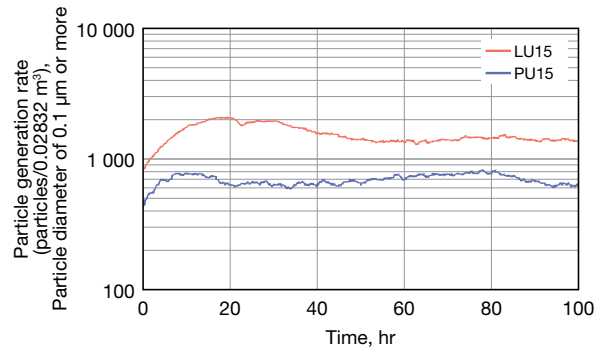

Fig. 1-2 Particle Generation Rate

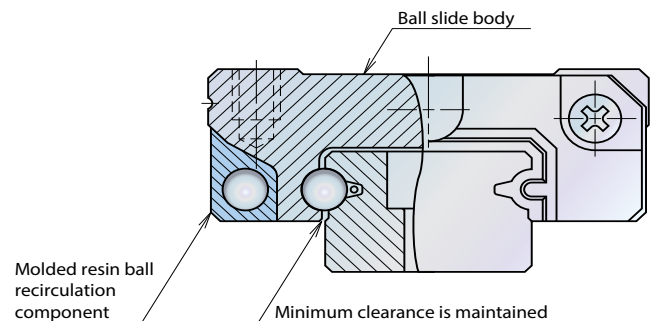



Fig. 2 Cross Sectional Front View

Developed for precision positioning tables, supporting cutting-edge equipment, including semiconductor manufacturing and medical devices

Reference Number

Reference numbers will be used as reference before finalizing all specifications. Please specify the reference number, except design serial number, to identify the product when ordering, requesting estimates, or inquiring about specifications from NSK.

Preloaded Assembly Type

| | | | | | | | | |
|--------------------|-------------|-------------------------|------------------------------|--|---------------------------------------|---|--|---|
| PU | 15 | 0470 | AL | K | 2 | -  | P5 | 1 |
| SERIES NAME | SIZE | RAIL LENGTH (MM) | BALL SLIDE SHAPE CODE | MATERIAL/SURFACE TREATMENT CODE K: Stainless Steel H: Stainless Steel + surface treatment | NUMBER OF BALL SLIDES PER RAIL | DESIGN SERIAL NUMBER | ACCURACY CODE P4: Super Precision P5: High Precision P6: Precision PN: Normal K4: Super Precision with K1 K5: High Precision with K1 K6: Precision with K1 KN: Normal with K1 | PRELOAD CODE 0: Fine Clearance - Z0 1: Slight Preload - Z1 |

Interchangeable Type

Reference number for rail and ball slide assembly

| | | | | | | | | |
|--------------------|-------------|-------------------------|------------------------------|--|---------------------------------------|--|--|---|
| PU | 15 | 0470 | AL | K | 2 | -  | PC | T |
| SERIES NAME | SIZE | RAIL LENGTH (MM) | BALL SLIDE SHAPE CODE | MATERIAL/SURFACE TREATMENT CODE K: Stainless Steel H: Stainless Steel + surface treatment | NUMBER OF BALL SLIDES PER RAIL | DESIGN SERIAL NUMBER | ACCURACY CODE PC: Normal KC: Normal with K1 | PRELOAD CODE T: Fine Clearance - ZT |

Reference number for ball slide of interchangeable type

| | | | | | |
|--|-------------|------------------------------|--|----------|---|
| PAU | 15 | AL | S | - | K |
| SERIES CODE PAU: PU Series Interchangeable Ball Slide PAE: PE Series Interchangeable Ball Slide | SIZE | BALL SLIDE SHAPE CODE | MATERIAL CODE S: Stainless Steel | | OPTION CODE K: Equipped with K1 |

Reference number for rail of interchangeable type

| | | | | | | | | |
|--|-------------|-------------------------|---|--|--|---------------------------------|------------------------------------|--|
| P1U | 15 | 0470 | R | K | N | - | PC | T |
| SERIES CODE P1U: PU Series Interchangeable Rail P1E: PE Series Interchangeable Rail | SIZE | RAIL LENGTH (MM) | RAIL SHAPE CODE S: PU09-12 R: PU15, PE09, 12 P: PE15 | MATERIAL/SURFACE TREATMENT CODE K: Stainless Steel H: Stainless Steel + surface treatment | BUTTING SPECIFICATION N: Non-butting rails L: Butting specification | DESIGN SERIAL NUMBER | ACCURACY CODE PC: Normal | PRELOAD CODE T: Fine Clearance - ZT |

* Please consult NSK for butting rail specification.

Accuracy Standard

We offer the following accuracy grades: Super precision grade P4, High precision grade P5, Precision grade P6, and Normal grade PN for preloaded assembly type, and Normal grade PC for interchangeable type.

Table 1 Tolerance of preloaded assembly

Unit: μm

| Characteristics | Accuracy grade | | | |
|--|----------------------------------|-------------------|--------------------|-----------------|
| | Super precision P4 | High precision P5 | Precision grade P6 | Normal grade PN |
| Mounting height H | ± 10 | ± 15 | ± 20 | ± 40 |
| Variation of H (All ball slides on a set of rails) | 5 | 7 | 15 | 25 |
| Mounting width W_2 or W_3 | ± 15 | ± 20 | ± 30 | ± 50 |
| Variation of W_2 or W_3 (All ball slides on reference rail) | 7 | 10 | 20 | 30 |
| Running parallelism of surface C to surface A | Shown in Table 3, Fig. 3, Fig. 4 | | | |
| Running parallelism of surface D to surface B | | | | |

Table 3 Running parallelism of ball slide

Unit: μm

| Rail length (mm) | Accuracy grade | | Preloaded assembly type | | | | Interchangeable type |
|------------------|----------------|-----------|-------------------------|-----|-----|-----|----------------------|
| | over | to (incl) | P4 | P5 | P6 | PN | PC |
| | 50 | | 2 | 2 | 4.5 | 6 | 6 |
| 50 | 80 | | 2 | 3 | 5 | 6 | 6 |
| 80 | 125 | | 2 | 3.5 | 5.5 | 6.5 | 6.5 |
| 125 | 200 | | 2 | 4 | 6 | 7 | 7 |
| 200 | 250 | | 2.5 | 5 | 7 | 8 | 8 |
| 250 | 315 | | 2.5 | 5 | 8 | 9 | 9 |
| 315 | 400 | | 3 | 6 | 9 | 11 | 11 |
| 400 | 500 | | 3 | 6 | 10 | 12 | 12 |
| 500 | 630 | | 3.5 | 7 | 12 | 14 | 14 |
| 630 | 800 | | 4.5 | 8 | 14 | 16 | 16 |
| 800 | 1 000 | | 5 | 9 | 16 | 18 | 18 |
| 1 000 | 1 250 | | 6 | 10 | 17 | 20 | 20 |

**Table 2 Tolerance of interchangeable type:
Normal grade PC**

Unit: μm

| Characteristics | Accuracy grade | Normal grade |
|---|-------------------------------------|--------------------------------------|
| | PC | |
| Mounting height H | | ± 20 |
| Variation of mounting height H | | 15 ¹⁾ 30 ²⁾ |
| Mounting width W_2 or W_3 | | ± 20 |
| Variation of mounting width W_2 or W_3 | | 20 |
| Running parallelism of surface C to surface A | Shown in Table 3, Fig. 3, Fig. 4 | |
| Running parallelism of surface D to surface B | | |

¹⁾ Variation on the same rail

²⁾ Variation on multiple rails

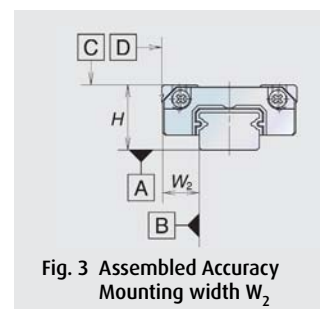

**Fig. 3 Assembled Accuracy
Mounting width W_2**

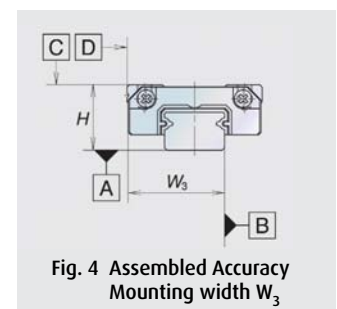

**Fig. 4 Assembled Accuracy
Mounting width W_3**

Preload and Rigidity

We offer three levels of preload: Slight preload (Z1) and Fine clearance (Z0) for preloaded assembly types, along with interchangeable types of Fine clearance (ZT). Values for preload and rigidity of the preloaded assembly types are shown in Tables 4 and 5.

Table 4 Preload and rigidity of preloaded assembly of PU series

| | Model No. | Preload (N) | | Rigidity (N / μ m) | |
|----------------|-----------|---------------------|--|------------------------|--|
| | | Slight preload (Z1) | | Slight preload (Z1) | |
| Standard type | PU05TR | 0 - 3 | | 17 | |
| | PU07AR | 0 - 8 | | 22 | |
| | PU09TR | 0 - 10 | | 30 | |
| | PU12TR | 0 - 17 | | 33 | |
| | PU15AL | 0 - 33 | | 45 | |
| High-load type | PU09UR | 0 - 14 | | 46 | |
| | PU12UR | 0 - 25 | | 52 | |
| | PU15BL | 0 - 51 | | 75 | |

Clearance of fine clearance Z0 is 0-3 μ m. Therefore, preload is zero. Clearance values of the interchangeable types are shown in Tables 6 and 7.

Table 6 Clearance of interchangeable type of PU Series

| Unit: μ m | | |
|----------------|-----------|-------------------|
| | Model No. | Fine clearance ZT |
| Standard type | PU09TR | 3 or less |
| | PU12TR | |
| | PU15AL | |
| High-load type | PU09UR | 5 or less |
| | PU12UR | |
| | PU15BL | |

Table 5 Preload and rigidity of preloaded assembly of PE series

| | Model No. | Preload (N) | | Rigidity (N / μ m) | |
|----------------|-----------|---------------------|--|------------------------|--|
| | | Slight preload (Z1) | | Slight preload (Z1) | |
| Standard type | PE05AR | 0 - 28 | | 45 | |
| | PE07TR | 0 - 29 | | 46 | |
| | PE09TR | 0 - 37 | | 61 | |
| | PE12AR | 0 - 40 | | 63 | |
| | PE15AR | 0 - 49 | | 66 | |
| High-load type | PE09UR | 0 - 54 | | 86 | |
| | PE12BR | 0 - 59 | | 97 | |
| | PE15BR | 0 - 75 | | 114 | |

Table 7 Clearance of interchangeable type of PE Series

| Unit: μ m | | |
|----------------|-----------|-------------------|
| | Model No. | Fine clearance ZT |
| Standard type | PE09TR | 3 or less |
| | PE12AR | |
| | PE15AR | |
| High-load type | PE09UR | 5 or less |
| | PE12BR | |
| | PE15BR | |

Shoulder Height H of the Mounting Surface and Corner Radius r

Figs. 5, 6 and Tables 8, 9 show the shoulder height and corner radius dimensions.

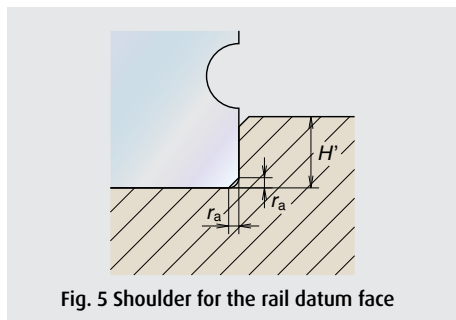

Fig. 5 Shoulder for the rail datum face

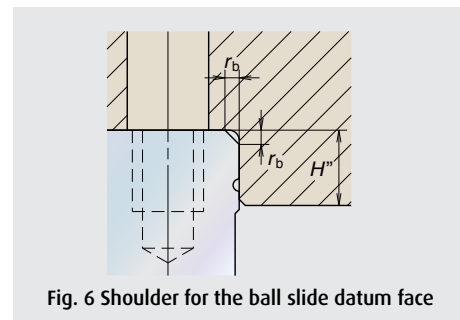

Fig. 6 Shoulder for the ball slide datum face

Table 8 Shoulder height H of the mounting surface and corner radius r (PU Series)

| Model No. | Corner radius (Maximum) | | Shoulder height | |
|-----------|-------------------------|-------|-----------------|-----------------|
| | r_a | r_b | H' | $H''(^{\circ})$ |
| | Unit: mm | | | |
| PU05 | 0.2 | 0.2 | 0.7 | 2.3 |
| PU07 | 0.2 | 0.3 | 1.2 | 2.5 |
| PU09 | 0.3 | 0.3 | 1.9 | 2.6 |
| PU12 | 0.3 | 0.3 | 2.5 | 3.4 |
| PU15 | 0.3 | 0.5 | 3.5 | 4.4 |

($^{\circ}$) H'' is the minimum recommended value based on the dimension T in Table 13.

Table 9 Shoulder height H of the mounting surface and corner radius r (PE Series)

| Model No. | Corner radius (Maximum) | | Shoulder height | |
|-----------|-------------------------|-------|-----------------|-----------------|
| | r_a | r_b | H' | $H''(^{\circ})$ |
| | Unit: mm | | | |
| PE05 | 0.2 | 0.2 | 1.1 | 2.5 |
| PE07 | 0.2 | 0.3 | 1.7 | 3.0 |
| PE09 | 0.3 | 0.3 | 3.5 | 2.8 |
| PE12 | 0.3 | 0.3 | 3.5 | 3.2 |
| PE15 | 0.3 | 0.5 | 3.5 | 4.1 |

($^{\circ}$) H'' is the minimum recommended value based on the dimension T in Table 14.

Lubrication

Selection of grease: Table 10 shows grease that is suitable for the PU series/PE series. NSK recommends PS2 as the standard grease for our miniature linear guides.

Table 10 Available Greases

| Grease code | Thickener | Base oil | Base oil kinematic viscosity mm ² /s (40°C) | Temperature range for use (°C) | Characteristic/Application |
|-------------|--------------|--|--|--------------------------------|---|
| PS2 | Lithium type | Synthetic oil + Synthetic hydrocarbon oil | 15.9 | -50 to 110 | • For low temperature operation • Suitable for high speed and light load application |
| LG2 | Lithium type | Mineral oil + Synthetic hydrocarbon oil | 32.0 | -20 to 70 | • For clean environment |
| LGU | Diurea type | Synthetic hydrocarbon oil | 95.8 | -30 to 120 | • For clean environment |

Long term maintenance free: NSK K1™ Lubrication unit enables long term maintenance free operation.

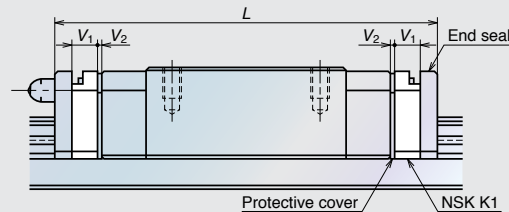

Table 11 Dimensions when equipped with NSK K1™ (PU Series)

Unit: mm

| | Model No. | Standard ball slide length | Ball slide length equipped with two NSK K1, L | Thickness of NSK K1, V ₁ | Thickness of protective cover, V ₂ |
|----------------|-----------|----------------------------|---|-------------------------------------|---|
| Standard type | PU05TR | 19.4 | 24.4 | 2 | 0.5 |
| | PU07AR | 23.4 | 29.4 | 2.5 | 0.5 |
| | PU09TR | 30 | 36.4 | 2.7 | 0.5 |
| | PU12TR | 35 | 42 | 3 | 0.5 |
| | PU15AL | 43 | 51.2 | 3.5 | 0.6 |
| High-load type | PU09UR | 41 | 47.4 | 2.7 | 0.5 |
| | PU12UR | 48.7 | 55.7 | 3 | 0.5 |
| | PU15BL | 61 | 69.2 | 3.5 | 0.6 |

Table 12 Dimensions when equipped with NSK K1™ (PE Series)

Unit: mm

| | Model No. | Standard ball slide length | Ball slide length equipped with two NSK K1, L | Thickness of NSK K1, V ₁ | Thickness of protective cover, V ₂ |
|----------------|-----------|----------------------------|---|-------------------------------------|---|
| Standard type | PE05AR | 24.1 | 28.9 | 2 | 0.4 |
| | PE07TR | 31.1 | 37.1 | 2.5 | 0.5 |
| | PE09TR | 39.8 | 46.8 | 3 | 0.5 |
| | PE12AR | 45 | 53 | 3.5 | 0.5 |
| | PE15AR | 56.6 | 66.2 | 4 | 0.8 |
| High-load type | PE09UR | 51.2 | 58.2 | 3 | 0.5 |
| | PE12BR | 60 | 68 | 3.5 | 0.5 |
| | PE15BR | 76 | 85.6 | 4 | 0.8 |

Ball slide length equipped with NSK K1™ = (Standard ball slide length) + (Thickness of NSK K1™, V₁ × Number of NSK K1™) + (Thickness of the protective cover, V₂ × 2)
Additional NSK K1™ units are available depending on the conditions of use.

Particle Resistance

End seal: Installed on both sides of the ball slide are a standard feature.

Bottom seal function: It is designed to minimize the clearance between the side faces of rail and the inner walls of the slide, and prevent foreign matters from entering the ball slide.

Applications

- › **Smoother motion and low particle generation**
Liquid crystal manufacturing and printed circuit board manufacturing devices
- › **Lightweight and low particle generation**
Semiconductor manufacturing devices (mounter, die bonder, and exposure device)
- › **Gentler tone and excellent particle resistant features**
Medical machinery and various precision devices

Dimensions

Rail and ball slide assembly (preloaded type, interchangeable type)

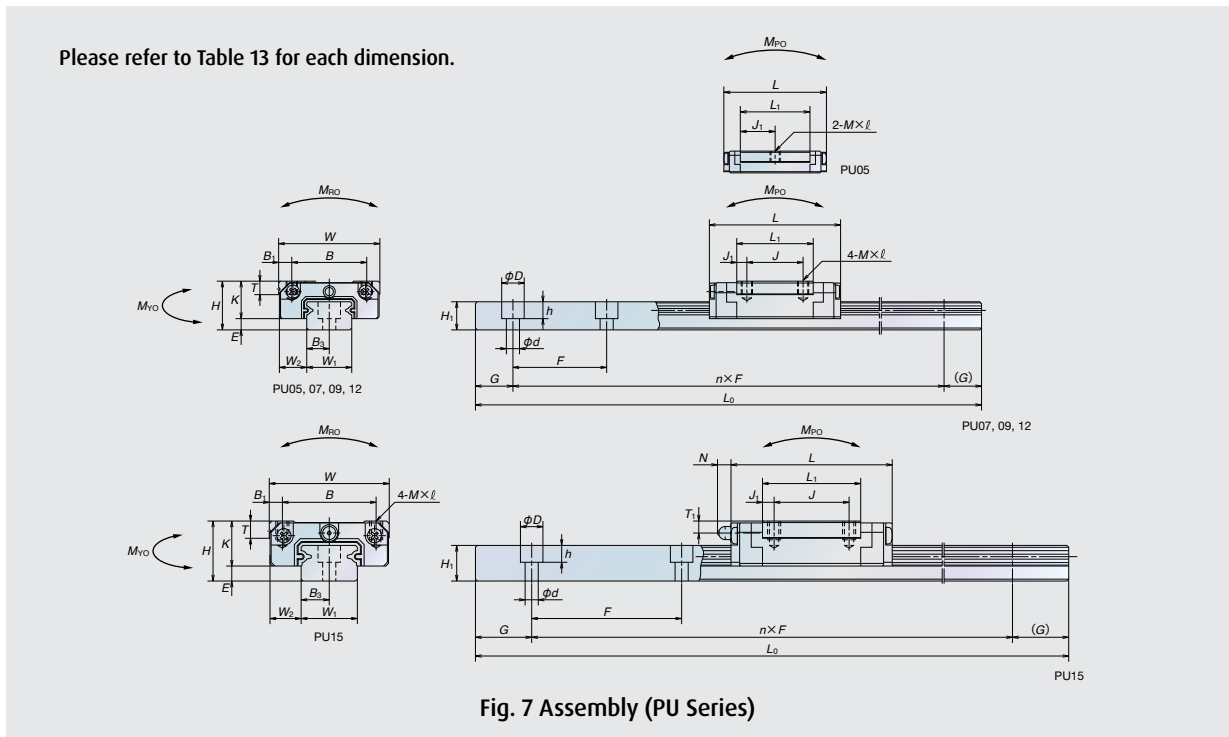

Table 13 Dimensions (PU Series)

| Model No. | Interchangeable type | Assembly | | | Ball slide | | | | | | | | | | | Rail | | | | |
|-----------|----------------------|----------|-----|----------------|------------|--------|---------------|----|------------|----------------|----------------|----------------|------|------|-------------------|-----------|---------------|-------|--------|-------|
| | | Height | E | W ₂ | Width | Length | Mounting hole | | | B ₁ | L ₁ | J ₁ | K | T | Oil hole | | | Width | Height | Pitch |
| | | | | | | | W | L | B | | | | | | J | M×Pitch×ℓ | Hole diameter | | | |
| PU05TR | — | 6 | 1.0 | 3.5 | 12 | 19.4 | 8 | — | M2×0.4×1.5 | 2.0 | 11.4 | 5.70 | 5.0 | 2.30 | Ø0.9 | 1.5 | — | 5 | 3.2 | 15 |
| PU07AR | — | 8 | 1.5 | 5.0 | 17 | 23.4 | 12 | 8 | M2×0.4×2.4 | 2.5 | 13.3 | 2.65 | 6.5 | 2.45 | Ø1.5 | 1.8 | — | 7 | 4.7 | 15 |
| PU09TR | ■ | 10 | 2.2 | 5.5 | 20 | 30.0 | 15 | 10 | M3×0.5×3 | 2.5 | 19.6 | 4.80 | 7.8 | 2.60 | — | — | — | 9 | 5.5 | 20 |
| PU09UR | ■ | 10 | 2.2 | 5.5 | 20 | 41.0 | 16 | 16 | M3×0.5×3 | 2.5 | 30.6 | 7.30 | 7.8 | 2.60 | — | — | — | 9 | 5.5 | 20 |
| PU12TR | ■ | 13 | 3.0 | 7.5 | 27 | 35.0 | 20 | 15 | M3×0.5×3.5 | 3.5 | 20.4 | 2.70 | 10.0 | 3.40 | — | — | — | 12 | 7.5 | 25 |
| PU12UR | ■ | 13 | 3.0 | 7.5 | 27 | 48.7 | 20 | 20 | M3×0.5×3.5 | 3.5 | 34.1 | 7.05 | 10.0 | 3.40 | — | — | — | 12 | 7.5 | 25 |
| PU15AL | ■ | 16 | 4.0 | 8.5 | 32 | 43.0 | 25 | 20 | M3×0.5×5 | 3.5 | 26.2 | 3.10 | 12.0 | 4.40 | Ø3 ⁽¹⁾ | 3.2 | (3.6) | 15 | 9.5 | 40 |
| PU15BL | ■ | 16 | 4.0 | 8.5 | 32 | 61.0 | 25 | 25 | M3×0.5×5 | 3.5 | 44.2 | 9.60 | 12.0 | 4.40 | Ø3 ⁽¹⁾ | 3.2 | (3.6) | 15 | 9.5 | 40 |

■: Interchangeable type is available.

(1) Drive-In grease fitting for Ø3 is available to PU15.

(2) Basic dynamic load rating is a load that allows for a 50-km rating fatigue life and is a vertical and constant load on the ball slide mounting surface. To convert C to C₁₀₀ for a 100-km rating fatigue life, divide C by 1.26.

Table 14 Dimensions (PE Series)

| Model No. | Interchangeable type | Assembly | | | Ball slide | | | | | | | | | | | Rail | | | | |
|-----------|----------------------|----------|-----|----------------|------------|--------|---------------|----|---------------|----------------|----------------|----------------|------|-----|---------------------|-----------|---------------|-------|--------|----------------|
| | | Height | E | W ₂ | Width | Length | Mounting hole | | | B ₁ | L ₁ | J ₁ | K | T | Oil hole | | | Width | Height | B ₂ |
| | | | | | | | W | L | B | | | | | | J | M×Pitch×ℓ | Hole diameter | | | |
| PE05AR | — | 6.5 | 1.4 | 3.5 | 17 | 24.1 | 13 | — | M2.5×0.45×1.5 | 2.0 | 16.4 | 8.2 | 5.1 | 2.5 | Ø0.9 | 1.3 | — | 10 | 4.0 | — |
| PE07TR | — | 9.0 | 2.0 | 5.5 | 25 | 31.1 | 19 | 10 | M3×0.5×2.8 | 3.0 | 20.8 | 5.4 | 7.0 | 3.0 | Ø1.9 | 1.9 | — | 14 | 5.2 | — |
| PE09TR | ■ | 12.0 | 4.0 | 6.0 | 30 | 39.8 | 21 | 12 | M3×0.5×3 | 4.5 | 26.6 | 7.3 | 8.0 | 2.8 | Ø2.0 | 2.3 | — | 18 | 7.5 | — |
| PE09UR | ■ | 12.0 | 4.0 | 6.0 | 30 | 51.2 | 23 | 24 | M3×0.5×3 | 3.5 | 38.0 | 7.0 | 8.0 | 2.8 | Ø2.0 | 2.3 | — | 18 | 7.5 | — |
| PE12AR | ■ | 14.0 | 4.0 | 8.0 | 40 | 45.0 | 28 | 15 | M3×0.5×4 | 6.0 | 31.0 | 8.0 | 10.0 | 3.2 | Ø2.5 | 2.7 | — | 24 | 8.5 | — |
| PE12BR | ■ | 14.0 | 4.0 | 8.0 | 40 | 60.0 | 28 | 28 | M3×0.5×4 | 6.0 | 46.0 | 9.0 | 10.0 | 3.2 | Ø2.5 | 2.7 | — | 24 | 8.5 | — |
| PE15AR | ■ | 16.0 | 4.0 | 9.0 | 60 | 56.6 | 45 | 20 | M4×0.7×4.5 | 7.5 | 38.4 | 9.2 | 12.0 | 4.1 | Ø3.0 ⁽³⁾ | 3.2 | (3.3) | 42 | 9.5 | 23 |
| PE15BR | ■ | 16.0 | 4.0 | 9.0 | 60 | 76.0 | 45 | 35 | M4×0.7×4.5 | 7.5 | 57.8 | 11.4 | 12.0 | 4.1 | Ø3.0 ⁽³⁾ | 3.2 | (3.3) | 42 | 9.5 | 23 |

■: Interchangeable type is available.

(3) Drive-In grease fitting for Ø3 is available to PE15.

(4) Basic dynamic load rating is a load that allows for a 50-km rating fatigue life and is a vertical and constant load on the ball slide mounting surface. To convert C to C₁₀₀ for a 100-km rating fatigue life, divide C by 1.26.

Please refer to Table 14 for each dimension.

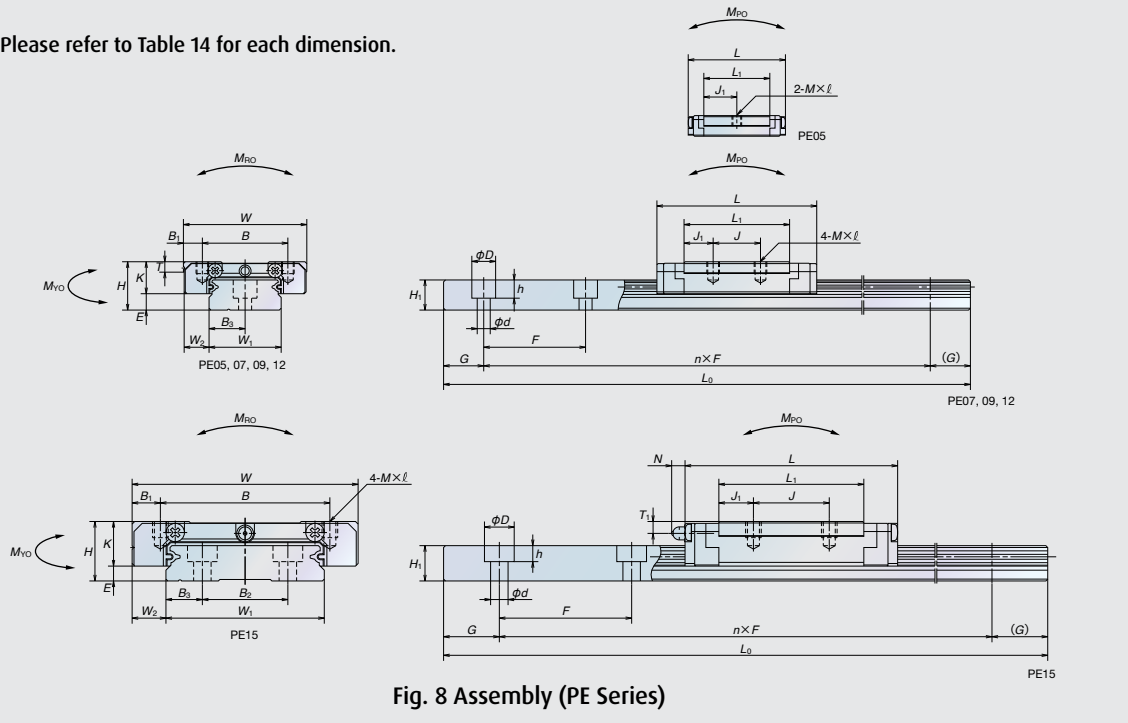

Fig. 8 Assembly (PE Series)

Unit: mm

| Rail | | | | Basic Load rating (²) | | | | | | | | Weight | |
|--------------------|----------------|-------------|-------------------------------------|------------------------------------|--------------------|-----------------|---------------------|-----------------------------|-----------------|-----------------------------|---------------------------------|------------|------|
| Mounting bolt hole | B ₃ | G | Maximum length L _{0max} | Dynamic | Static | M _{RO} | Static moment (N-m) | | | | Ball diameter D _w | Weight | |
| | | | | C (N) | C ₀ (N) | | M _{PO} | | M _{YO} | | | Ball slide | Rail |
| d×D×h | (Reference) | (Reference) | | | | | one slide | two slides in close contact | one slide | two slides in close contact | (g) | (g/100 mm) | |
| 2.3×3.3×0.8 | 2.5 | 5.0 | 210 | 520 | 775 | 2.06 | 1.28 | 9.90 | 1.28 | 9.90 | 1.0000 | 4 | 11 |
| 2.4×4.2×2.3 | 3.5 | 5.0 | 375 | 1 090 | 1 370 | 5.20 | 2.70 | 21.80 | 2.70 | 21.8 | 1.5875 | 8 | 23 |
| 3.5×6×4.5 | 4.5 | 7.5 | 600 | 1 490 | 2 150 | 9.90 | 6.10 | 41.00 | 6.10 | 41.0 | 1.5875 | 16 | 35 |
| | | | | 2 100 | 3 500 | 16.20 | 15.60 | 88.00 | 15.60 | 88.0 | | | |
| 3.5×6×4.5 | 6.0 | 10.0 | 800 | 2 830 | 3 500 | 21.10 | 11.40 | 73.50 | 11.40 | 73.5 | 2.3812 | 32 | 65 |
| | | | | 4 000 | 5 700 | 34.50 | 28.30 | 174.00 | 28.30 | 174.0 | | | |
| 3.5×6×4.5 | 7.5 | 15.0 | 1 000 | 5 550 | 6 600 | 49.50 | 25.60 | 190.00 | 25.60 | 190.0 | 3.1750 | 59 | 105 |
| | | | | 8 100 | 11 300 | 84.50 | 69.50 | 435.00 | 69.50 | 435.0 | | | |

To fix rails of PU05TR, use M2 × 0.4 cross-recessed pan head machine screw for precision instrument.
(JCS 10-70 No. 0 pan head machine screw No. 1) (JCS: Japanese Camera Industrial Standard)

Unit: mm

| Rail | | | | | Basic load rating (⁴) | | | | | | | | Weight | |
|-------|--------------------|----------------|-------------|-------------------------------------|------------------------------------|--------------------|-----------------|---------------------|-----------------------------|-----------------|-----------------------------|---------------------------------|------------|------|
| Pitch | Mounting bolt hole | B ₃ | G | Maximum length L _{0max} | Dynamic | Static | M _{RO} | Static moment (N-m) | | | | Ball diameter D _w | Weight | |
| | | | | | C (N) | C ₀ (N) | | M _{PO} | | M _{YO} | | | Ball slide | Rail |
| F | d×D×h | (Reference) | (Reference) | | | | | one slide | two slides in close contact | one slide | two slides in close contact | (g) | (g/100 mm) | |
| 20 | 3×5×1.6 | 5.0 | 7.5 | 150 | 690 | 1 160 | 6.0 | 2.75 | 17.5 | 2.75 | 17.5 | 1.0000 | 7 | 34 |
| 30 | 3.5×6×3.2 | 7.0 | 10.0 | 600 | 1 580 | 2 350 | 16.7 | 7.20 | 46.0 | 7.20 | 46.0 | 1.5875 | 19 | 55 |
| 30 | 3.5×6×4.5 | 9.0 | 10.0 | 800 | 3 000 | 4 500 | 36.5 | 17.3 | 113.0 | 17.3 | 113.0 | 2.0000 | 35 | 95 |
| | | | | | 4 000 | 6 700 | 54.5 | 37.5 | 210.0 | 37.5 | 210.0 | | | |
| 40 | 4.5×8×4.5 | 12.0 | 15.0 | 1 000 | 4 350 | 6 350 | 70.5 | 29.3 | 180.0 | 29.3 | 180.0 | 2.3812 | 66 | 140 |
| | | | | | 5 800 | 9 550 | 106.0 | 63.5 | 345.0 | 63.5 | 345.0 | | | |
| 40 | 4.5×8×4.5 | 9.5 | 15.0 | 1 200 | 7 600 | 10 400 | 207.0 | 59.0 | 370.0 | 59.0 | 370.0 | 3.1750 | 140 | 275 |
| | | | | | 10 300 | 16 000 | 320.0 | 135.0 | 740.0 | 135.0 | 740.0 | | | |

To fix rails of PE05AR, use M2.5 × 0.45 cross-recessed pan head machine screw for precision instrument.
(JCS 10-70 No. 0 pan head machine screw No. 3) (JCS: Japanese Camera Industrial Standard)

Interchangeable type

Ball slide of interchangeable types

Please refer to Table 13 for each dimension.

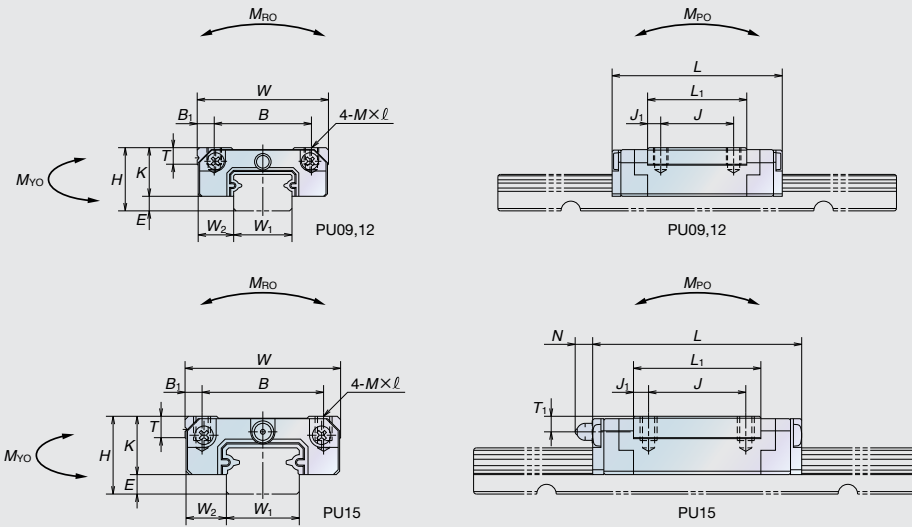

Fig. 9 Ball slide of interchangeable types (PU Series)

Please refer to Table 14 for each dimension.

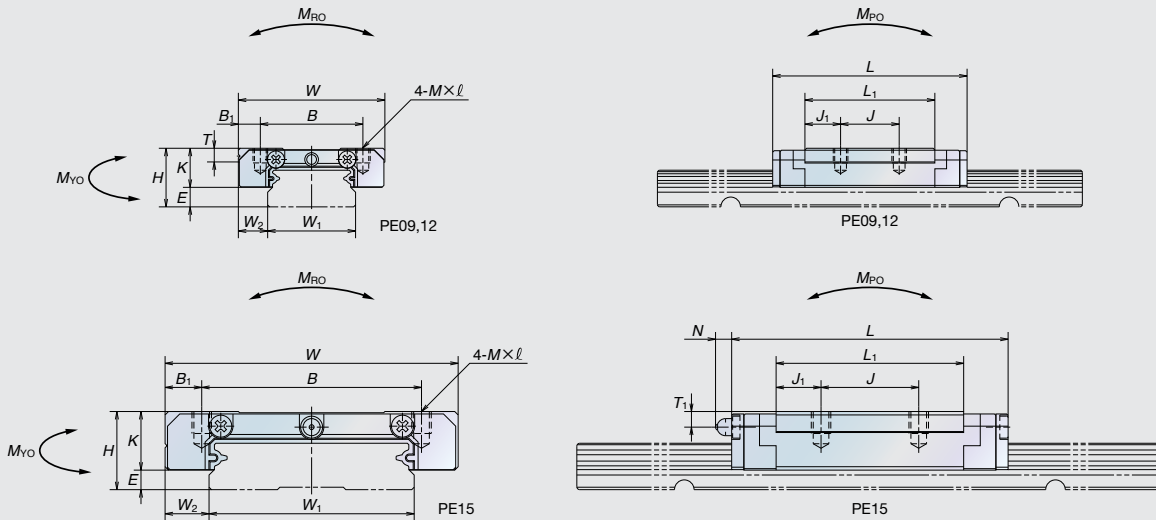

Fig. 10 Ball slide of interchangeable types (PE Series)

Rail of interchangeable types

Please refer to Table 13 for each dimension.

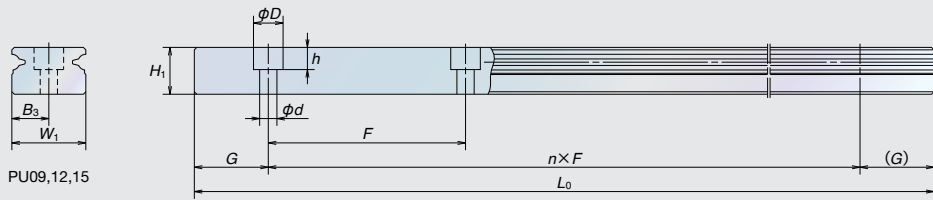

Fig. 11 Rail of interchangeable types (PU Series)

Please refer to Table 14 for each dimension.

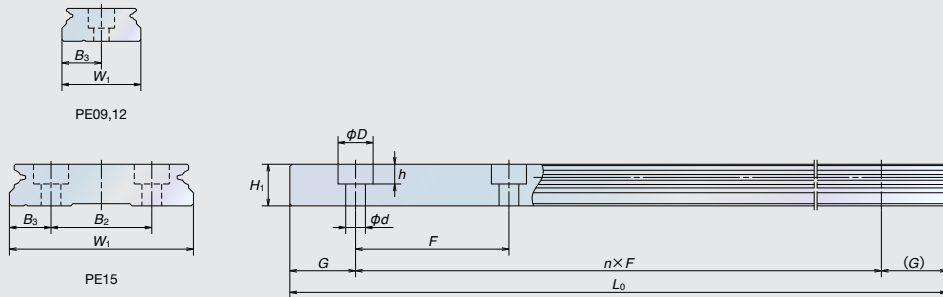

Fig. 12 Rail of interchangeable types (PE Series)

Interchangeability with LU Series/LE Series

The PU series/PE series is designed to be interchangeable* with the LU series/LE series for its mounting dimensions and load ratings.

Refer to Figs. 7, 8 and Tables 13, 14 for more details.

(*) Load ratings for PU05 and PE05 are not interchangeable

Handling Precautions

- › NSK Linear Guides may become damaged when struck or hit.
- › Maximum operating temperature must be 80°C or below. Exceeding this limit may damage resin parts.
- › Maximum operating temperature must be 50°C (max. momentary 80°C) when attaching NSK K1™. Also, avoid exposure to organic solvents with a degreasing effect. Do not immerse in kerosene or rust preventative oil (with kerosene ingredients).
- › Handling of interchangeable types
 - Interchangeable ball slide will be delivered on a provisional rail (installing fixture).
 - Be sure to use the provisional rail when mounting ball slide(s) on to a rail.
 - Do not remove the ball slide from provisional rail until sliding on to a rail.