

Type MGDA

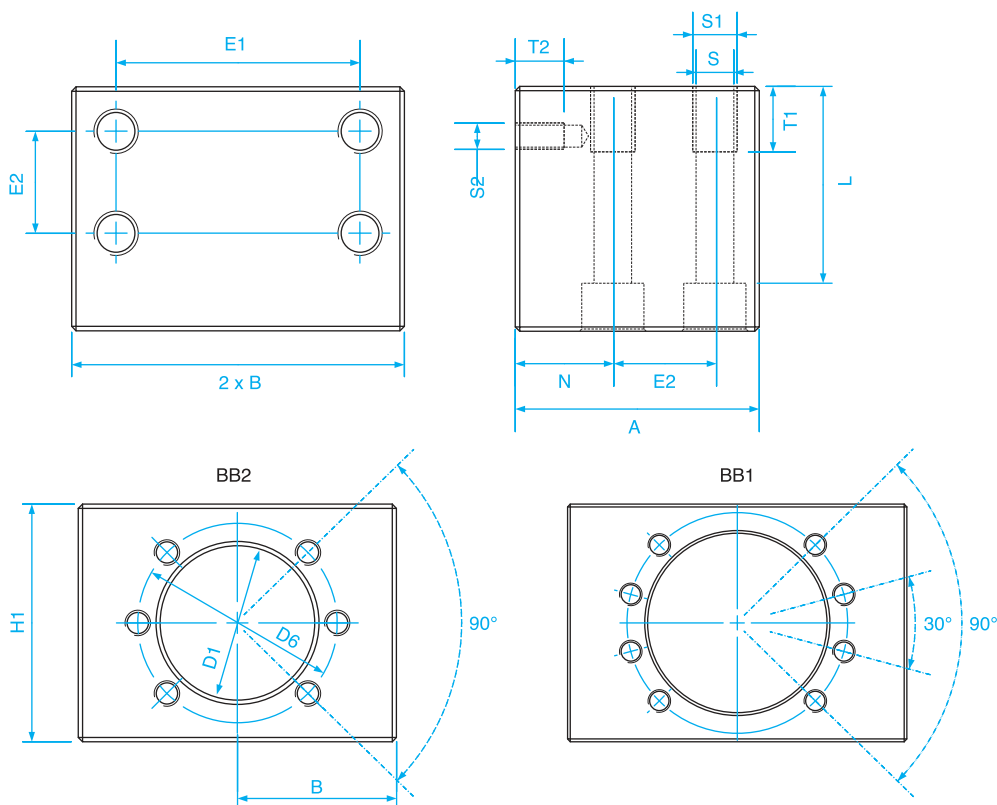

Vis à billes

Référence Type	Dimensions - mm															Forme	ISO 4762	Poids Weight
	D1 +/-0,1	D6	A	B +/-0,1	H +/-0,1	H1	E1 +/-0,1	E2 +/-0,1	N	S	S1	T1	S2	T2	L			
	g																	
MGDA16	28,4	38	50	35	24	48	50	20	20	8,4	M10	15	M5	10	37	BB2	M8	910
MGDA20	36,4	47	55	37,5	28	56	55	23	22	8,4	M10	15	M6	11	45	BB2	M8	1180
MGDA25	40,4	51	55	40	30	60	60	23	22	8,4	M10	15	M6	11	49	BB2	M8	1330
MGDA32	50,4	65	70	50	35	70	75	30	27	13	M16	20	M8	14	52	BB2	M12	2770
MGDA40	63,4	78	80	60	42	80	90	35	31	15	M18	25	M8	17	66	BB1	M12	3610

Type				
MGDA16	MGDA20	MGDA25	MGDA32	MGDA40
SFNUR16	SFNUR20	SFNUR25	SFNUR32	SFNUR40
SFNUL16	SFNUL20	SFNUL25	SFNUL32	SFNUL40
SND16	SND20	SND25	SND32	SND40
SFAR16	SFAR20	SFAR25	SFAR32	SFAR40